

Receptacle, M12, Push-Pull outer locking, male, straight, 4 poles, D-coded, back wall-mounting, print contact, Industrial Ethernet

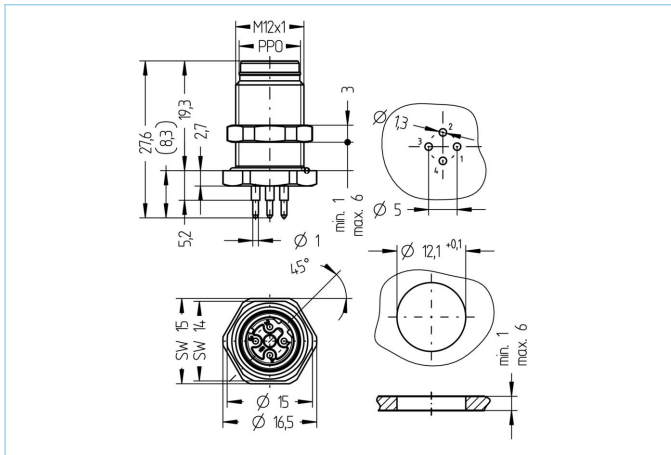

Product data

Item description	IE-PPOFHM12SUD4-P/M12
Item-No.	8120592
Customs tariff-No.	85444290
Packaging unit	10
Step-File	IE-PPOFHM12SUD4-P_M12.stp
EAN	4047106341923

Technical data

Connector	male, straight, M12
Number of pins	4
Coding	D
Rated voltage	60V DC
Current load per pin (at 40°C)	4A
Insulation resistance	≥10 ⁹ Ω
Transmission features	Cat5e
Ambient temperature product	-30°C...+90°C
Reflow	2 min. 250 °C
Contact material	Metal, CuZn, gold-plated
Contact-carrier material	Plastic, PA GF, GN
Receptacle housing material	Metal, CuZn, nickel-plated
Material of external sealing	NBR
Mounting direction	Back wall-mounting (incl. Fixing screw)
Wrench size of fastening nut	A/F14
Fastening thread	M12x1
Wall thickness area fixing nut	1,0...6,0 mm

Connecting type	Print contact
Standards	IEC 61076-2-010
Degree of protection (mounted)	IP65, IP67, IP68
Mechanical life-cycle	>100 mating cycles
Degree of pollution	3
Style	straight
Tightening torque housing/flange	1,5 Nm

Classification

eCl@ss 6.0	27279220
eCl@ss 7.0	27440103
eCl@ss 8.0	27440103
eCl@ss 9.0	27440103
ETIM 5.0	EC002061
ETIM 6.0	EC002061

Link to product

<https://www.escha.net/en/8120592>