

SCOPE OF APPLICATION | APPLICATION

Field-wireable M12 connectors
Change of the contour of the coupling nut

PCN23_007

CURRENT DESIGN

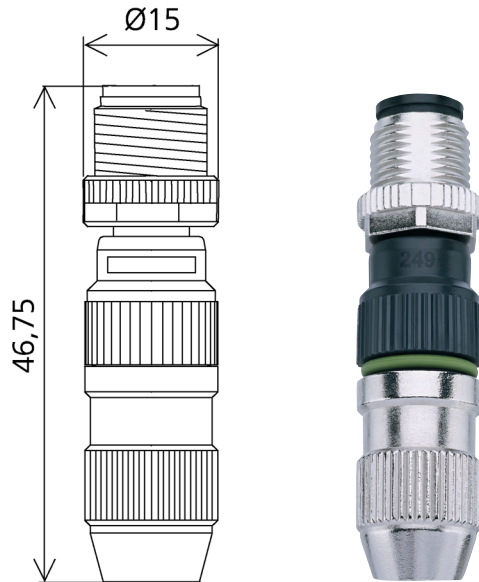

NEW DESIGN

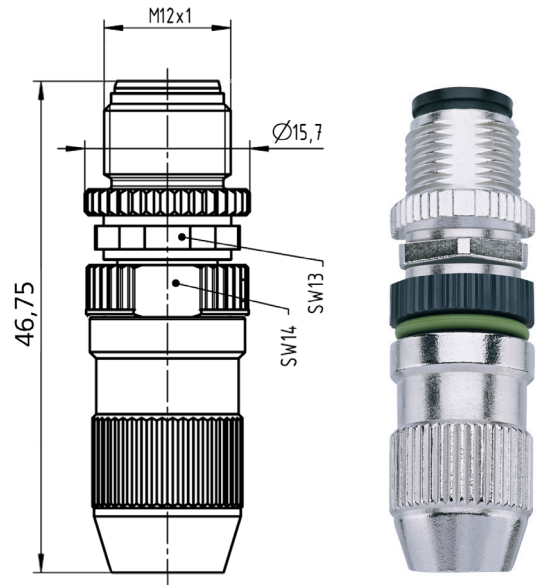

MODIFICATION

In order to increase long-term availability of the products a slight change of the geometry of the coupling nut is necessary.

CONFIRMATION OF WARRANTED CHARACTERISTICS

All guaranteed electrical- and mechanical characteristics are not affected by these modifications.

DATE OF MODIFICATION

The changes will be implemented on 15 September 2023

Mixed deliveries may occur as the item numbers remain the same so stock and changed products may be included in the same shipment

AFFECTED ITEM

Item number	Item description
8019712	WASC3S
8019716	WASC4S

Director Product Management

Marc Braun

Compliance Officer

Quality Management Representative

Achim Rudack