

**SCOPE OF APPLICATION | APPLICATION**  
 Design change of M23 female 12 poles

**PCN23\_004**

**CURRENT DESIGN**

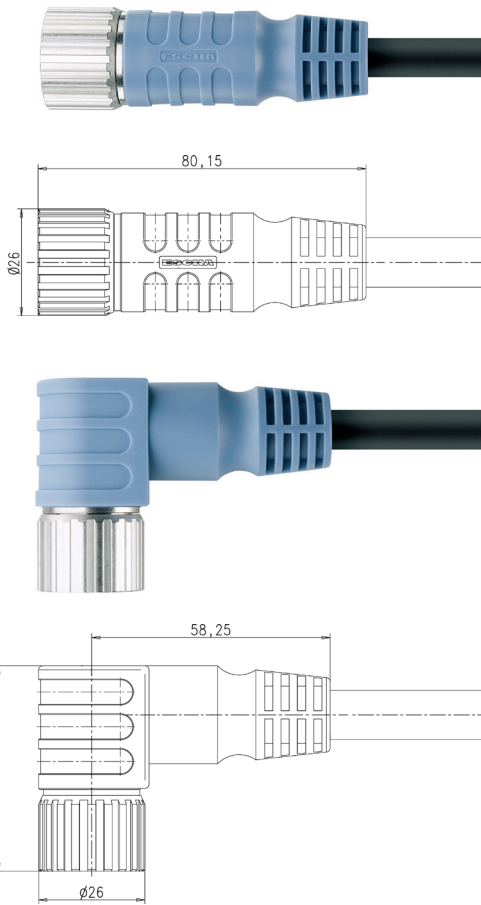

**NEW DESIGN**

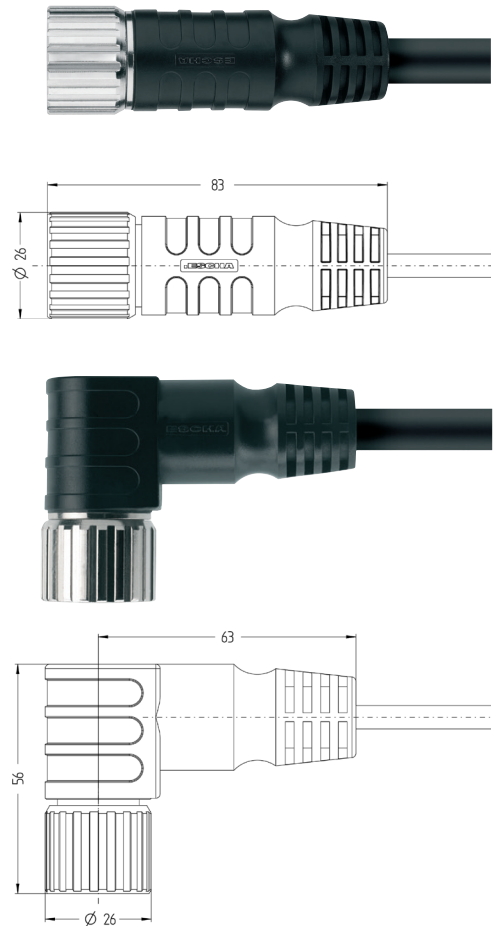

**MODIFICATION**

In order to ensure long-term and secure delivery capability, ESCHA has decided to adapt this product to standard components. External dimensions are only slightly affected.

- Black overmolding
- Black contact carrier

**CONFIRMATION OF WARRANTED CHARACTERISTICS**

All guaranteed electrical- and mechanical characteristics are not affected by these modifications.

**DATE OF MODIFICATION**

- The changes will be implemented on 31 May 2023
- Mixed deliveries may occur as the item numbers remain the same so stock and changed products may be included in the same shipment

**AFFECTED ITEM**

See detached Excel file

Director Product Management

Marc Braun

Compliance Officer

Quality Management Representative  
 Achim Rudack