

SCOPE OF APPLICATION | APPLICATION

Design changes of M12 Power receptacles

CURRENT DESIGN

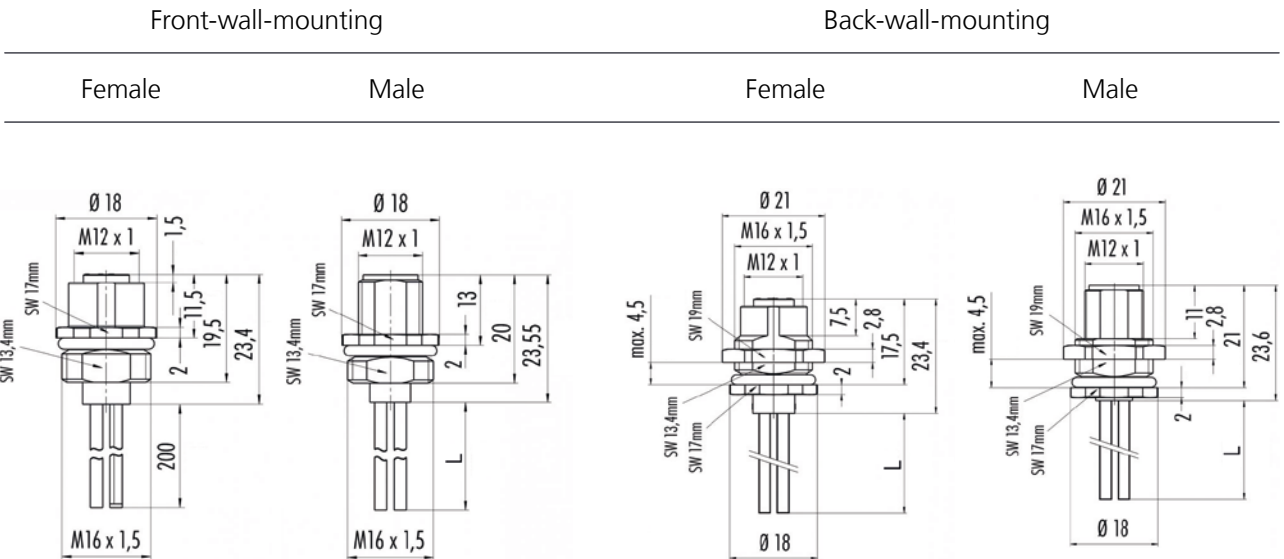

NEW DESIGN

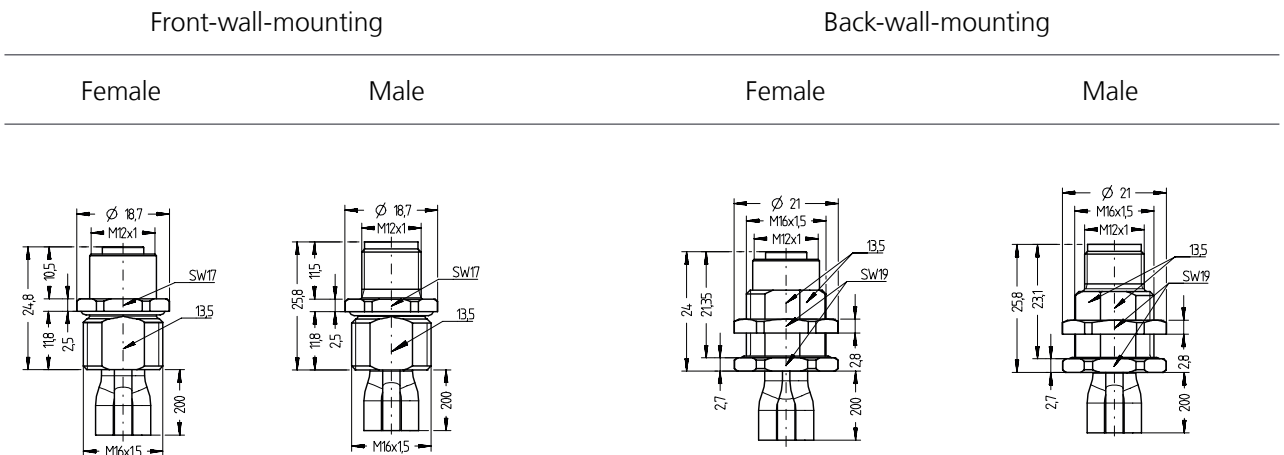

MODIFICATION

Due to increase long-term availability, an adjustment of the supply-chain is necessary.

- Marginal adjustments:
 - Housing geometry
 - Material of wire insulation
 - Color of wire insulation
 - Marking of wires

CONFIRMATION OF WARRANTED CHARACTERISTICS

- All major characteristics are not affected

DATE OF MODIFICATION

- 01. May 2022
- Mixed deliveries are possible

AFFECTED ITEMS

- See detached Excel file

Director Product Management

Marc Braun

Compliance Officer

Quality Management Representative

Achim Rudack